

455B NZ

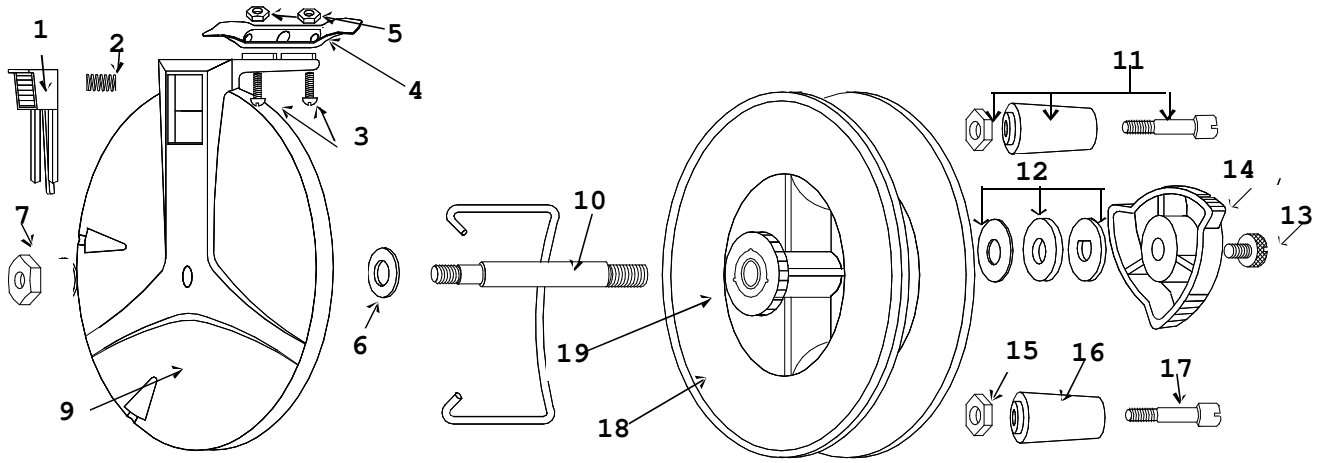

Key No	Description	Part No
1	Ratchet Button	R5E9
2	Ratchet Button Spring	R5H2
3	Base Screw	R2D4
4	Brass Base	R2C4
5	Bas Hex Nut	R2F2
6	Fibre Washer	R6J1
7	Spindle Hex Nut	R6F1
9	Cross & Back Assembly(reel less spool & handles)	RIA455B
10	Spindle	R6A1NZ
11	Handle Assembly	R4F13
12	Spindle Washer Set	R6L1
13	Spindle Screw	R6E1
14	Spindle Knob	R6B11
15	Handle Nut	R4G1
16	Handle	R4D6
17	Handle Screw	R4E4
18	Spool Assembly (Includes Handles)	R4B455B
19	Ratchet Wheel	R5B6